

PRORIL

50Hz

Designed for light weight, excellent performance, low energy consumption, and easy maintenance, PRORIL submersible handy pumps serve a wide range of pumping applications on utility, construction, industrial, and municipal job sites.

Handy and Residue Pump

SMART VOX 400/750

Handy Pump



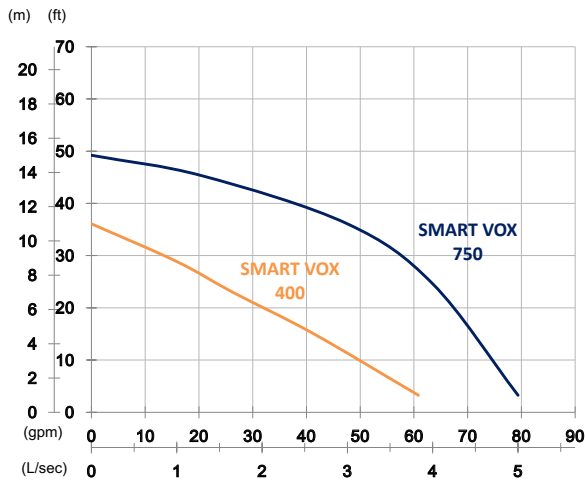

	SMART VOX 400	SMART VOX 750
OUTPUT	0.4 kW (0.5 HP)	0.75 kW (1 HP)
OUTLET	2" (50 mm)	2" (50 mm)
SOLID PASSAGE	7 mm	7 mm
Weight	12 kg	13 kg
HEAD	Rated: 7 m Max: 11 m	Rated: 11 m Max: 15 m
FLOW	Rated: 1.6 L/s Max: 3.8 L/s	Rated: 3 L/s Max: 5 L/s

Pump Type		Electric Submersible Pumps
Motor	Phase	1-Phase, 3-Phase
	Type	Induction Motor
	Poles	2 Pole (2850 rpm)
	Insulation	Class F
	Protector	Miniature Thermal Protector Circle Thermal Protector
Starter Method		1-Phase · Capacitor-Run, 3-Phase · D.O.L
Lubricant		Food Grade (ISO VG32)
Specs.	Impeller Type	Opened
	Shaft Seal	Double Mechanical Seal
		Silicon Carbide VS Ceramic/Carbon
	Bearings	C3 Shielded ball bearings
Cable	H07RN-F	
	10 m or longer upon request	
Materials	Pump Casing	Gray Iron
	Impeller	Synthetic Polymers
	Motor Frame	Aluminum
	Motor Shaft	Stainless Steel
	Agitator	Stainless Steel
Strainer	Synthetic Polymers	
Max. Liquid Temperature		40°C (104°F)
Max. Submersion Depth		20 m (66 ft)
pH Range		pH 5 - pH 8

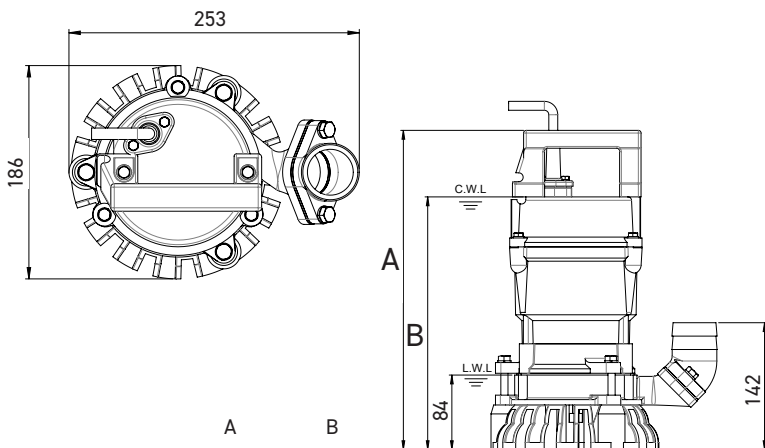

	A	B
SMART VOX 400	358	283
SMART VOX 750	385	310

unit : mm

C.W.L : Continuous running water level

L.W.L : Lowest running water level